

SAVE TIME & REDUCE ERRORS WITH OUR ONLINE BROACH G-CODE GENERATOR!

More Programming Information available at www.cncbroachtools.com

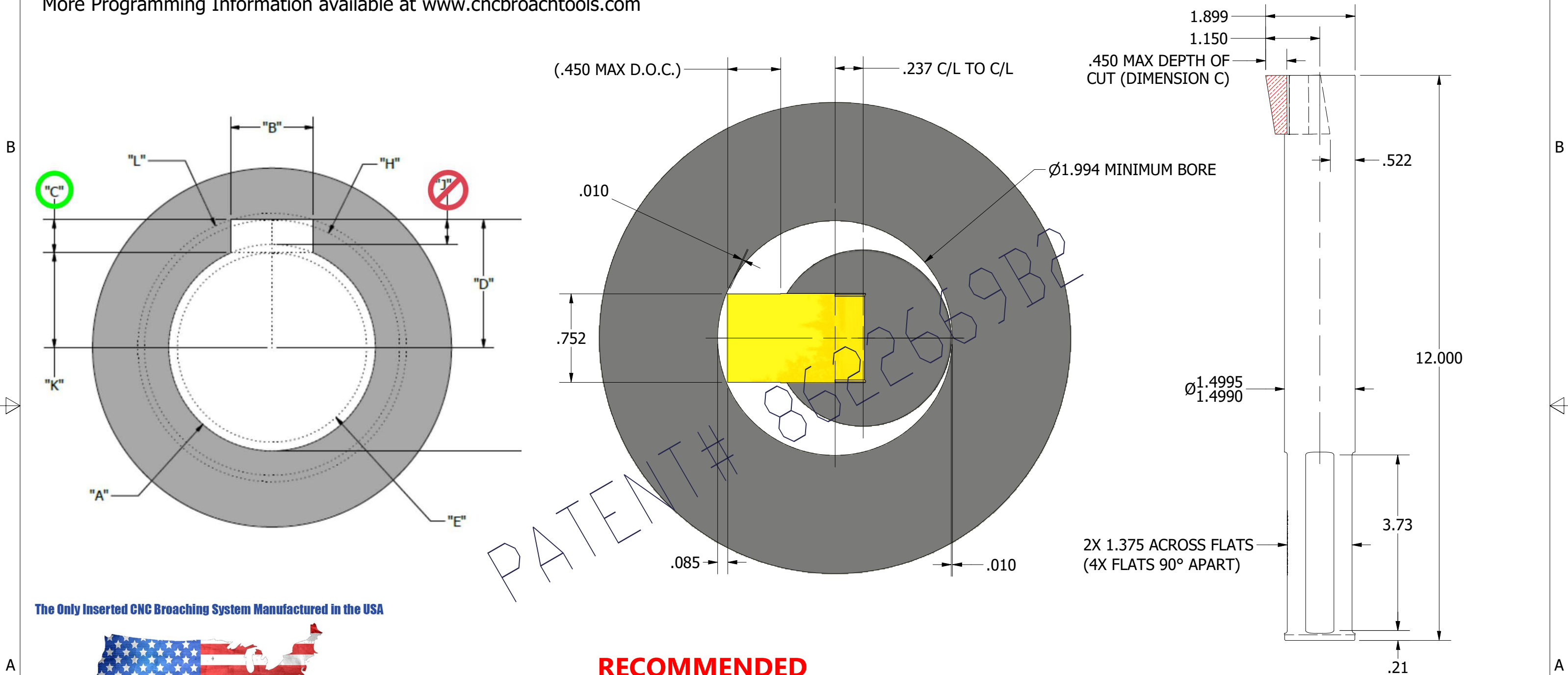

The Only Inserted CNC Broaching System Manufactured in the USA



The Design of CNC Broach Tools and Inserts are Proprietary and Protected by USA Patent #8,622,669,B2

CNC Broach Tool LLC
sales@cncbroachtools.com

877-248-1631
www.cncbroachtools.com

**RECOMMENDED
SET SCREW
TORQUE: 40 IN-LB**

PATENT# 8622669B2

PROPRIETARY AND CONFIDENTIAL
THE INFORMATION CONTAINED IN THIS DRAWING IS THE SOLE PROPERTY OF CNC BROACH TOOL LLC. ANY REPRODUCTION IN PART OR AS A WHOLE WITHOUT THE WRITTEN PERMISSION OF CNC BROACH IS PROHIBITED.

UNLESS OTHERWISE SPECIFIED: DIMENSIONS ARE IN INCHES TOLERANCES: FRACTIONAL ± .005 ANGULAR: MACH ± .1° BEND ± .1° TWO PLACE DECIMAL ± .010 THREE PLACE DECIMAL ± .005	DRAWN SMA 03/20/21	NAME SMA	DATE 03/20/21
INTERPRET GEOMETRIC TOLERANCING PER: MATERIAL 17-4PH S.S.	CHECKED XX XX/XX/XX	ENG APPR.	
FINISH BLACK OXIDE	MFG APPR.	Q.A.	
DO NOT SCALE DRAWING	COMMENTS:		



TITLE: T75L BROACH TOOL DETAIL			
SIZE B	DWG. NO. T75L	REV C	
WEIGHT:		SHEET 1 OF 1	