

SAVE TIME & REDUCE ERRORS WITH OUR ONLINE BROACH G-CODE GENERATOR!

More Programming Information available at www.cncbroachtools.com

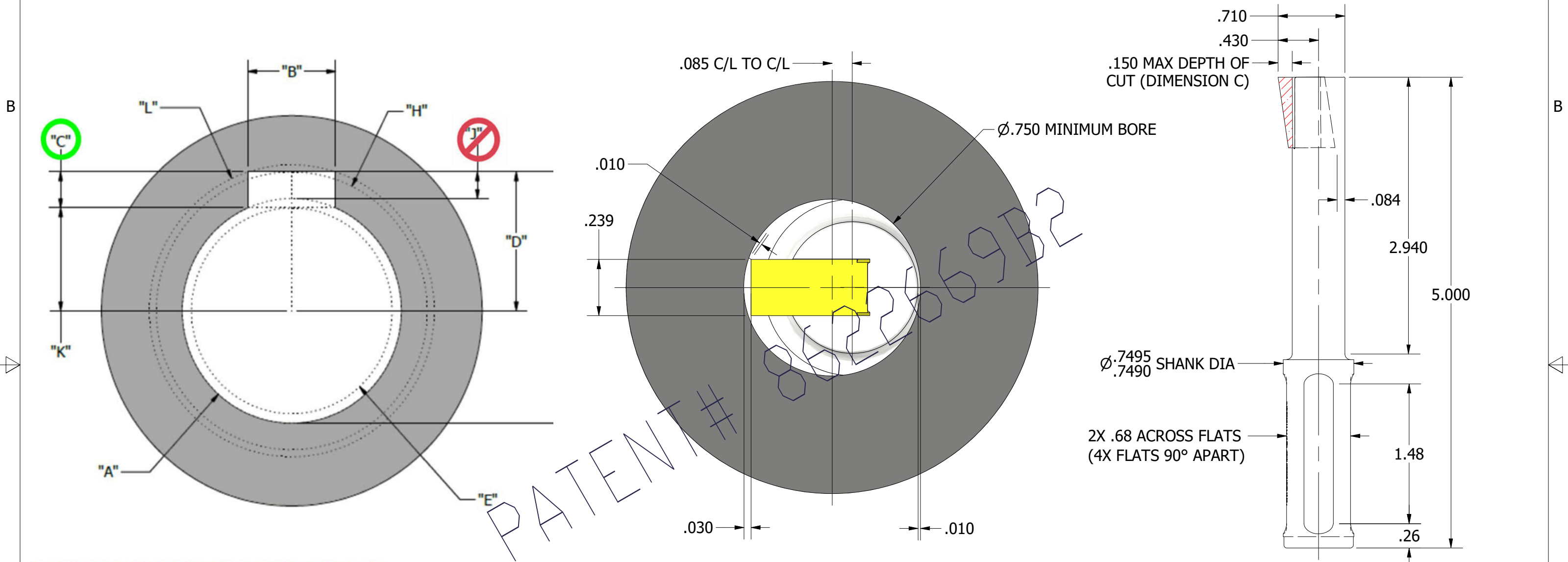

The Only Inserted CNC Broaching System Manufactured in the USA



The Design of CNC Broach Tools and Inserts are Proprietary and Protected by USA Patent #8,622,669,B2

CNC Broach Tool LLC
sales@cncbroachtools.com

877-248-1631
www.cncbroachtools.com

**RECOMMENDED
SET SCREW
TORQUE: 22 IN-LB**

PATENT# 8622669B2

PROPRIETARY AND CONFIDENTIAL
THE INFORMATION CONTAINED IN THIS DRAWING IS THE SOLE PROPERTY OF CNC BROACH. ANY REPRODUCTION IN PART OR AS A WHOLE WITHOUT THE WRITTEN PERMISSION OF CNC BROACH IS PROHIBITED.

UNLESS OTHERWISE SPECIFIED:		NAME	DATE
DIMENSIONS ARE IN INCHES		DRAWN	SMA 03/20/21
TOLERANCES:		CHECKED	XX XX/XX/XX
FRACTIONAL $\pm .005$		ENG APPR.	
ANGULAR: MACH $\pm .01$ BEND $\pm .01$		MFG APPR.	
TWO PLACE DECIMAL $\pm .010$		Q.A.	
THREE PLACE DECIMAL $\pm .005$		COMMENTS:	
INTERPRET GEOMETRIC TOLERANCING PER:			
MATERIAL			
17-4PH S.S.			
FINISH			
BLACK OXIDE			
DO NOT SCALE DRAWING			



TITLE: T6MML BROACH TOOL DETAIL			
SIZE	DWG. NO.	REV	
B	T6MML	D	
WEIGHT:			SHEET 1 OF 1