

More Programming Information available at [www.cncbroachtools.com](http://www.cncbroachtools.com)

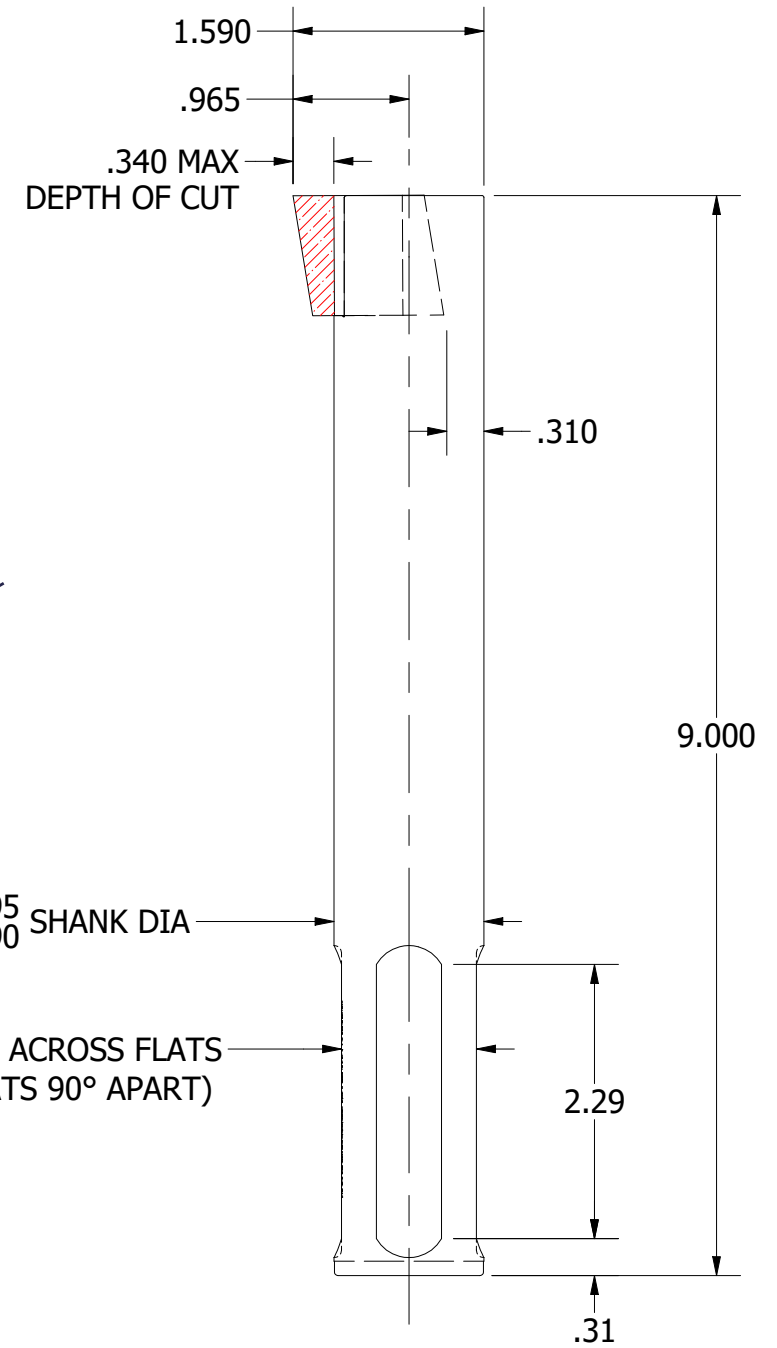

The Only Inserted CNC Broaching System Manufactured in the USA

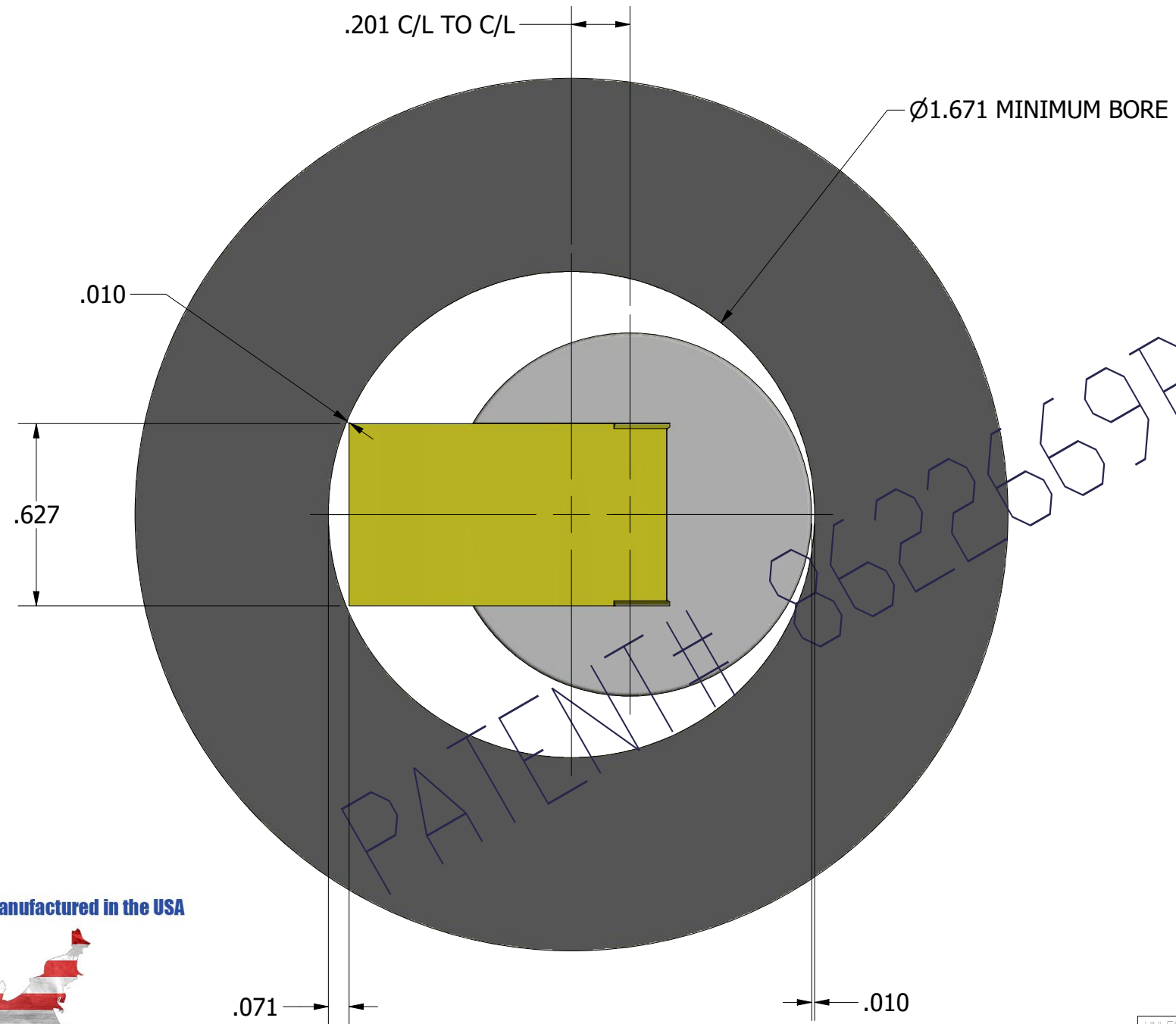

The Design of CNC Broach Tools and Inserts are Proprietary and Protected by USA Patent #8,622,669,B2

CNC Broach Tool LLC  
sales@cncbroachtools.com

877-248-1631  
www.cncbroachtools.com

PATENT# 8622669B2

PROPRIETARY AND CONFIDENTIAL  
THE INFORMATION CONTAINED IN THIS DRAWING IS THE SOLE PROPERTY OF CNC BROACH TOOL. ANY REPRODUCTION IN PART OR AS A WHOLE WITHOUT THE WRITTEN PERMISSION OF CNC BROACH IS PROHIBITED.

UNLESS OTHERWISE SPECIFIED: DIMENSIONS ARE IN INCHES TOLERANCES: FRACTIONAL ± .005 ANGULAR: MACH ± .1° BEND ± .010 TWO PLACE DECIMAL ± .010 THREE PLACE DECIMAL ± .005	DRAWN	SMA	03/20/21
	CHECKED	XX	XX/XX/XX
	ENG APPR.		
	MFG APPR.		
	Q & A		
INTERPRET GEOMETRIC TOLERANCING PER:	COMMENTS:		
MATERIAL	17-4PH S.S.		
FINISH	BLACK OXIDE		
DO NOT SCALE DRAWING			



TITLE: T58L BROACH TOOL DETAIL			
SIZE	DWG. NO.	REV	
B	T58L	C	
WEIGHT:		SHEET 1 OF 1	