

More Programming Information available at www.cncbroachtools.com

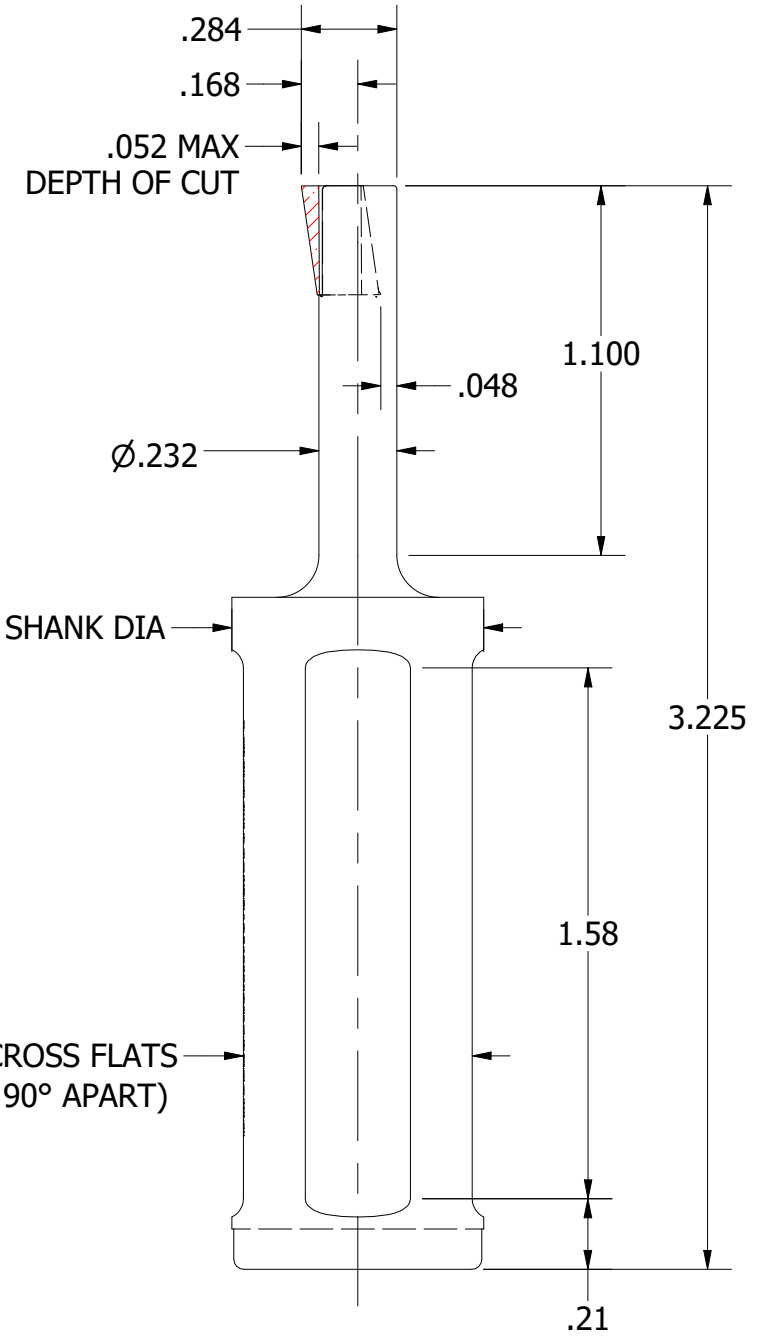

The Only Inserted CNC Broaching System Manufactured in the USA

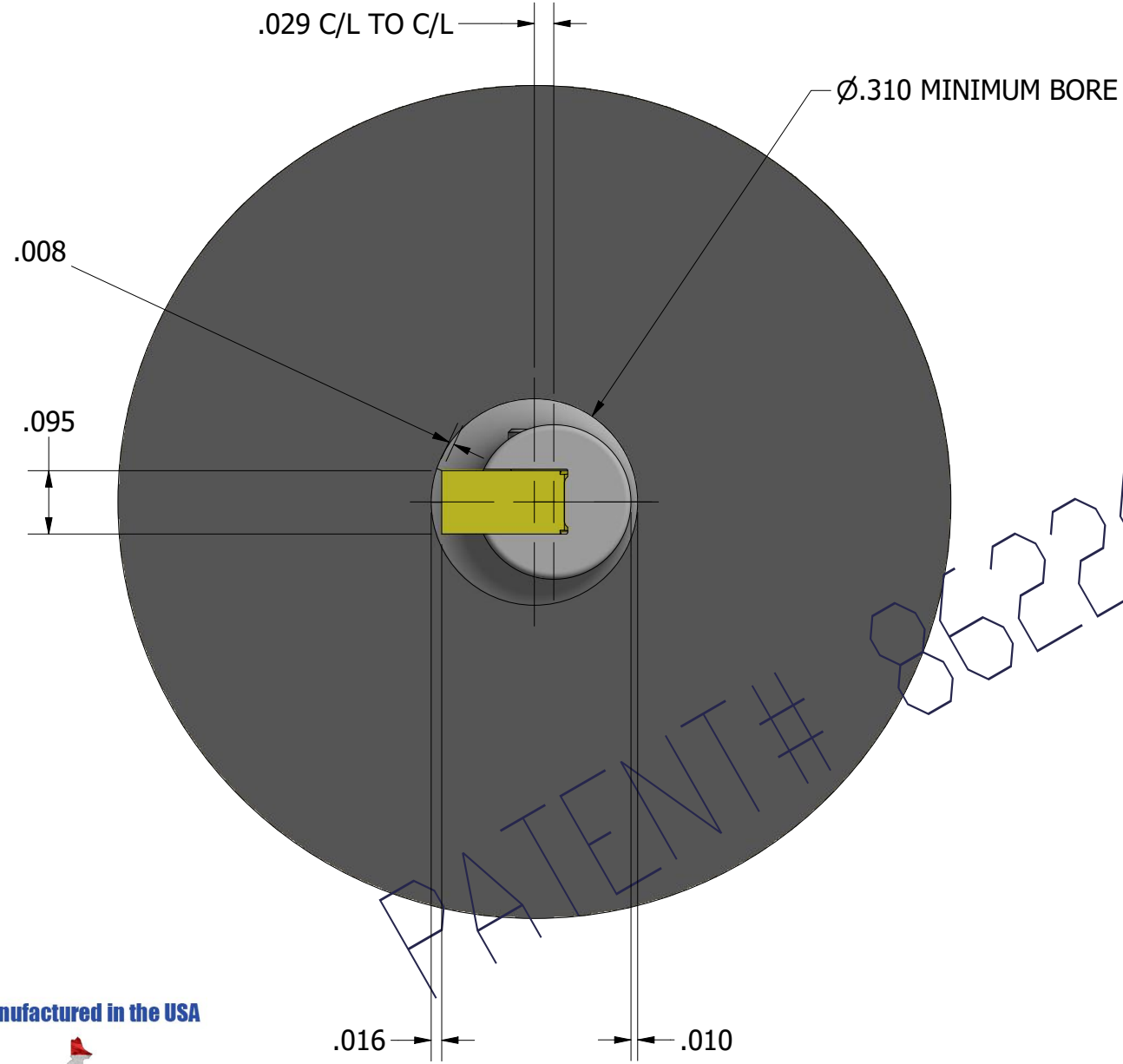

The Design of CNC Broach Tools and Inserts are Proprietary and Protected by USA Patent #8,622,669,B2

CNC Broach Tool LLC
sales@cncbroachtools.com

877-248-1631
www.cncbroachtools.com

PATENT# 8622669B2

PROPRIETARY AND CONFIDENTIAL
THE INFORMATION CONTAINED IN THIS DRAWING IS THE SOLE PROPERTY OF CNC BROACH. ANY REPRODUCTION IN PART OR AS A WHOLE WITHOUT THE WRITTEN PERMISSION OF CNC BROACH IS PROHIBITED.

UNLESS OTHERWISE SPECIFIED: DIMENSIONS ARE IN INCHES TOLERANCES: FRACTIONAL ± .005 ANGULAR: MACH ± .1° BEND ± .1° TWO PLACE DECIMAL ± .010 THREE PLACE DECIMAL ± .005	NAME	DATE
	DRAWN SMA	03/20/21
	CHECKED XX	XX/XX/XX
	ENG APPR.	
	MFG APPR.	
INTERPRET GEOMETRIC TOLERANCING PER:	Q & A	
MATERIAL 17-4PH S.S.	COMMENTS:	
FINISH BLACK OXIDE		
DO NOT SCALE DRAWING		



TITLE: T564L BROACH TOOL DETAIL		
SIZE DWG. NO. B T564L	REV B	WEIGHT: SHEET 1 OF 1