

SAVE TIME & REDUCE ERRORS WITH OUR ONLINE BROACH G-CODE GENERATOR!

More Programming Information available at www.cncbroachtools.com

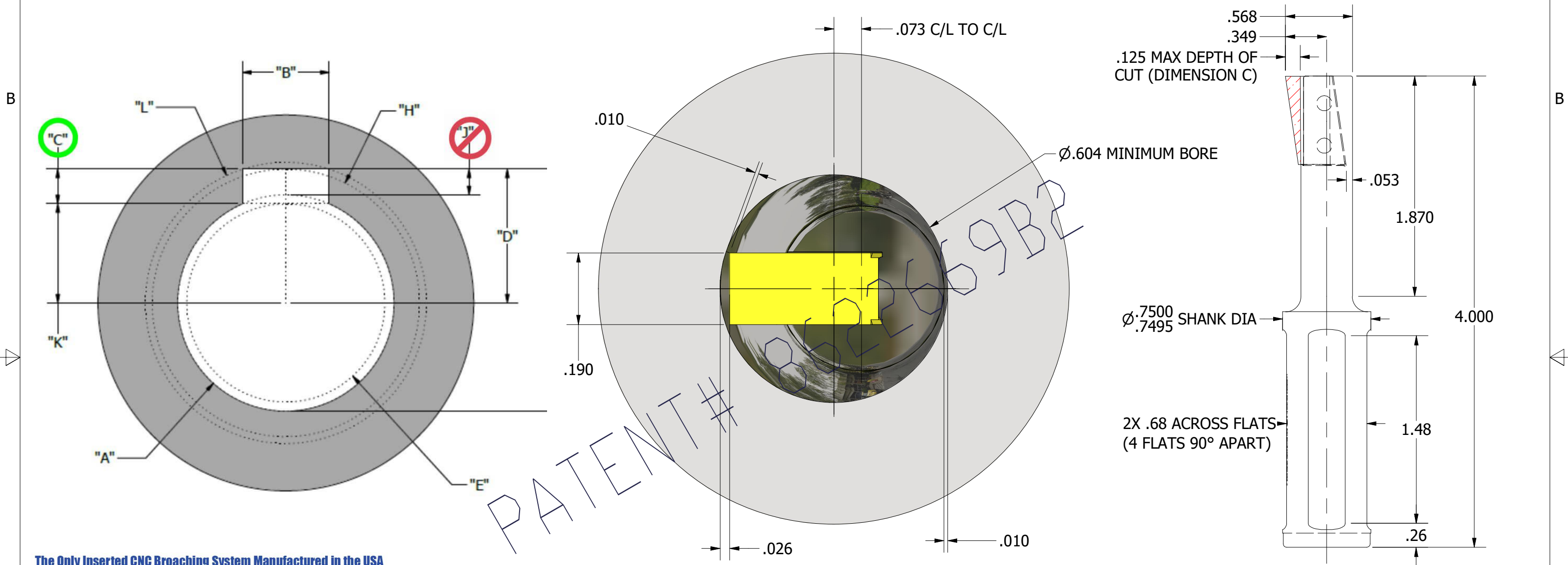

The Only Inserted CNC Broaching System Manufactured in the USA



The Design of CNC Broach Tools and Inserts are Proprietary and Protected by USA Patent #8,622,669,B2

CNC Broach Tool LLC
sales@cncbroachtools.com

877-248-1631
www.cncbroachtools.com

**RECOMMENDED
SET SCREW
TORQUE: 20 IN-LB**

PATENT# 8622669B2

PROPRIETARY AND CONFIDENTIAL
THE INFORMATION CONTAINED IN THIS
DRAWING IS THE SOLE PROPERTY OF
CNC BROACH TOOL. ANY REPRODUCTION IN
PART OR AS A WHOLE WITHOUT THE
WRITTEN PERMISSION OF
CNC BROACH IS PROHIBITED.

UNLESS OTHERWISE SPECIFIED:		NAME	DATE
DIMENSIONS ARE IN INCHES		DRAWN	SMA 05/14/25
TOLERANCES:		CHECKED	
FRACTIONAL ±		ENG APPR.	
ANGULAR: MACH ± .1° BEND ±		MFG APPR.	
TWO PLACE DECIMAL ± .010		Q.A.	
THREE PLACE DECIMAL ± .005		COMMENTS:	
INTERPRET GEOMETRIC TOLERANCING PER:			
MATERIAL			
17-4PH S.S.			
FINISH			
BLACK OXIDE			
DO NOT SCALE DRAWING			



TITLE:			
T316SM BROACH TOOL DETAIL			
SIZE	DWG. NO.	REV	
B	T316SM	A	
WEIGHT:			SHEET 1 OF 1