

More Programming Information available at [www.cncbroachtools.com](http://www.cncbroachtools.com)

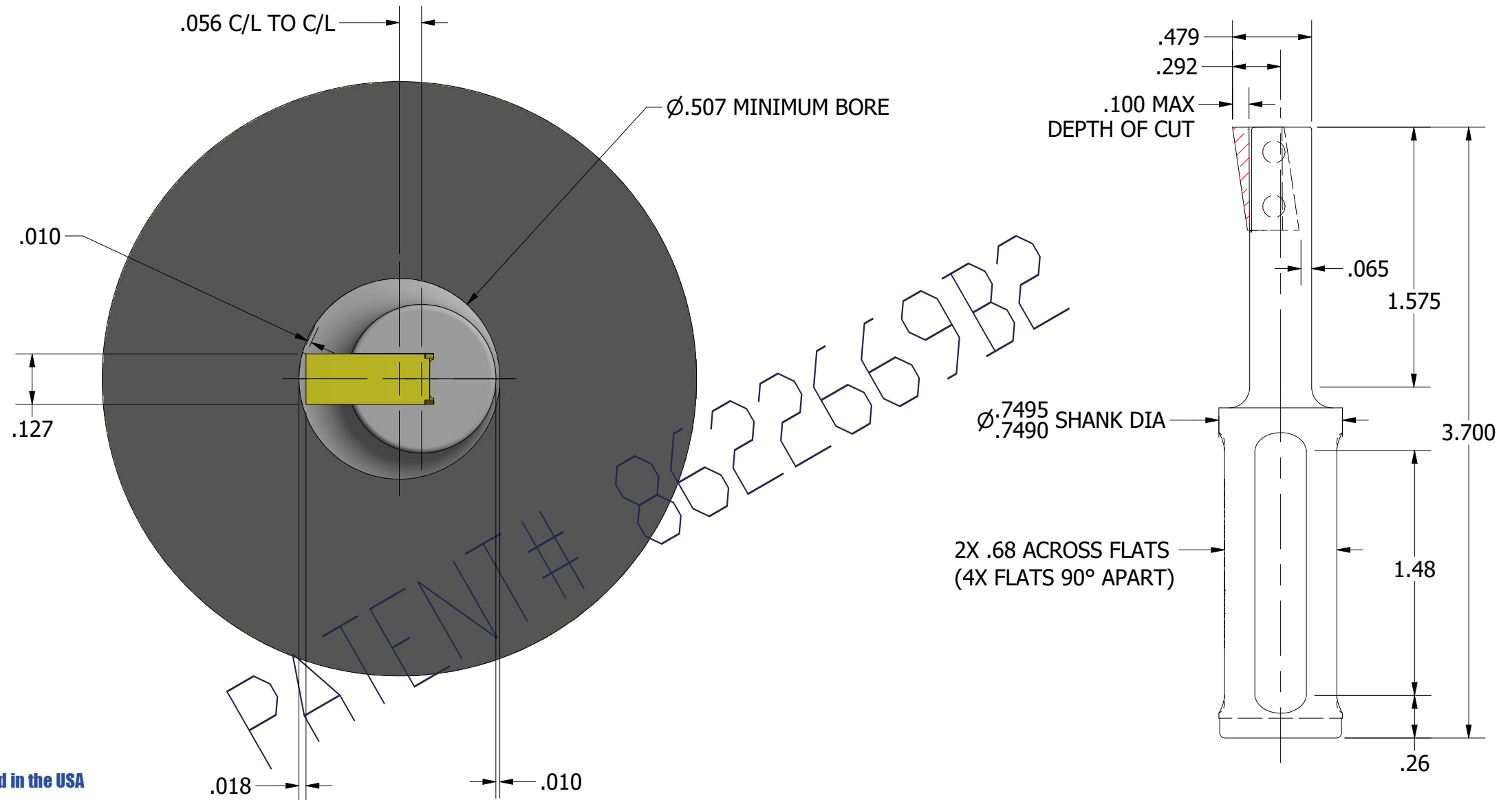

The Only Inserted CNC Broaching System Manufactured in the USA



The Design of CNC Broach Tools and Inserts are Proprietary and Protected by USA Patent #8,622,669,B2

CNC Broach Tool LLC  
sales@cncbroachtools.com

877-248-1631  
www.cncbroachtools.com

PATENT# 8622669B2

PROPRIETARY AND CONFIDENTIAL  
THE INFORMATION CONTAINED IN THIS DRAWING IS THE SOLE PROPERTY OF CNC BROACH TOOL LLC. ANY REPRODUCTION IN PART OR AS A WHOLE WITHOUT THE WRITTEN PERMISSION OF CNC BROACH TOOL LLC IS PROHIBITED.

UNLESS OTHERWISE SPECIFIED:		NAME	DATE
DIMENSIONS ARE IN INCHES		DRAWN	SMA 03/20/21
TOLERANCES:		CHECKED	XX XX/XX/XX
FRACTIONAL ± .005		ENG APPR.	
ANGULAR: MACH ± .1° BEND ± .1°		MFG APPR.	
TWO PLACE DECIMAL ± .010		Q.A.	
THREE PLACE DECIMAL ± .005		COMMENTS:	
INTERPRET GEOMETRIC TOLERANCING PER:			
MATERIAL			
17-4PH S.S.			
FINISH			
BLACK OXIDE			
DO NOT SCALE DRAWING			



TITLE:		
T18L BROACH TOOL DETAIL		
SIZE	DWG. NO.	REV
B	T18L	C
WEIGHT:		SHEET 1 OF 1