

SAVE TIME & REDUCE ERRORS WITH OUR ONLINE BROACH G-CODE GENERATOR!

More Programming Information available at www.cncbroachtools.com

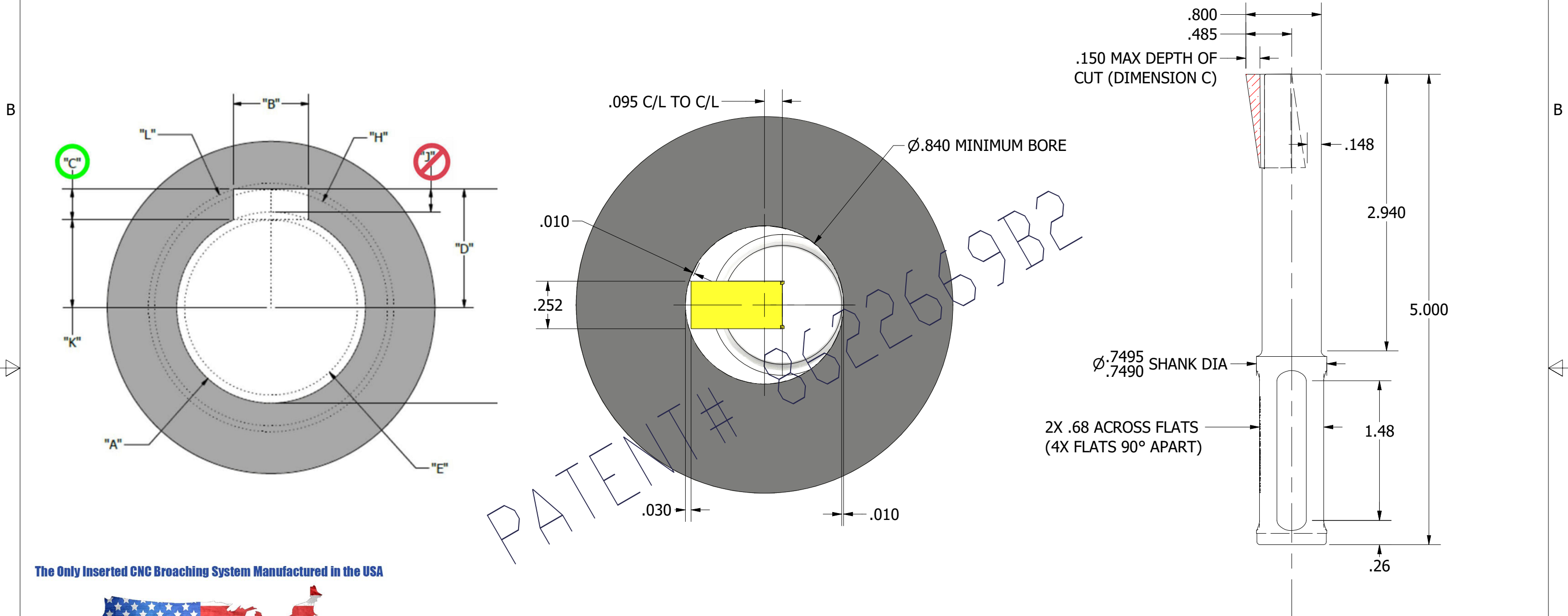

PATENT # 8622669B2
 PATENT # 8622669B2

The Only Inserted CNC Broaching System Manufactured in the USA



The Design of CNC Broach Tools and Inserts are Proprietary and Protected by USA Patent #8,622,669,B2

CNC Broach Tool LLC
sales@cncbroachtools.com

877-248-1631
www.cncbroachtools.com

**RECOMMENDED
SET SCREW
TORQUE: 30 IN-LB**

PATENT# 8622669B2

PROPRIETARY AND CONFIDENTIAL
THE INFORMATION CONTAINED IN THIS DRAWING IS THE SOLE PROPERTY OF CNC BROACH TOOL LLC. ANY REPRODUCTION IN PART OR AS A WHOLE WITHOUT THE WRITTEN PERMISSION OF CNC BROACH TOOL LLC IS PROHIBITED.

UNLESS OTHERWISE SPECIFIED: DIMENSIONS ARE IN INCHES TOLERANCES: FRACTIONAL ± .005 ANGULAR: MACH ± .1° BEND ± .1° TWO PLACE DECIMAL ± .010 THREE PLACE DECIMAL ± .005	DRAWN	SMA	03/20/21
	CHECKED	XX	XX/XX/XX
	ENG APPR.		
	MFG APPR.		
INTERPRET GEOMETRIC TOLERANCING PER:	Q.A.		
MATERIAL 17-4PH S.S.	COMMENTS:		
FINISH BLACK OXIDE			
DO NOT SCALE DRAWING			



TITLE: T14L BROACH TOOL DETAIL			
SIZE B	DWG. NO. T14L	REV D	
WEIGHT:		SHEET 1 OF 1	