

More Programming Information available at [www.cncbroachtools.com](http://www.cncbroachtools.com)

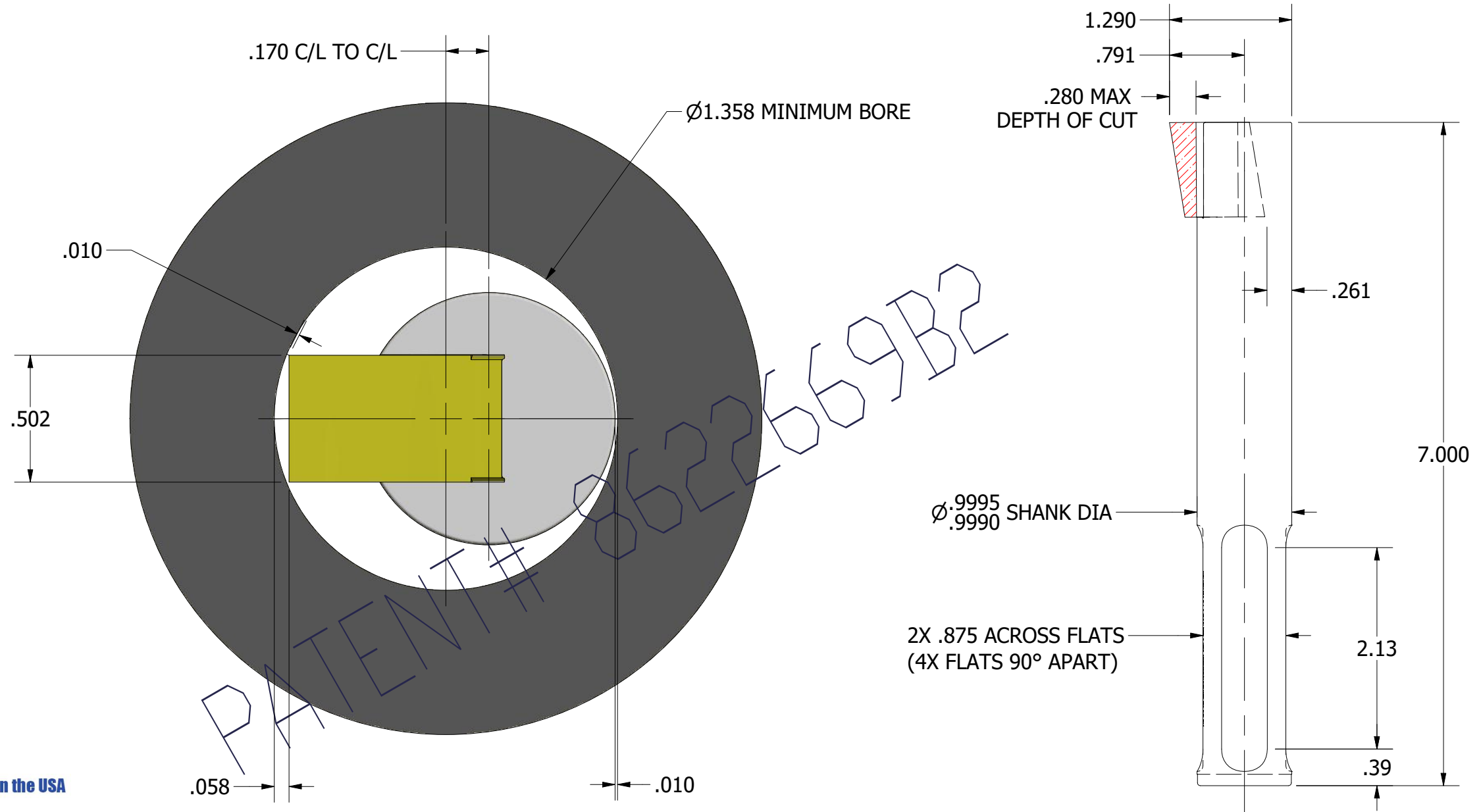

The Only Inserted CNC Broaching System Manufactured in the USA



The Design of CNC Broach Tools and Inserts are Proprietary and Protected by USA Patent #8,622,669,B2

CNC Broach Tool LLC  
sales@cncbroachtools.com

877-248-1631  
www.cncbroachtools.com

PATENT# 8622669B2

PROPRIETARY AND CONFIDENTIAL  
THE INFORMATION CONTAINED IN THIS DRAWING IS THE SOLE PROPERTY OF CNC BROACH TOOL LLC. ANY REPRODUCTION IN PART OR AS A WHOLE WITHOUT THE WRITTEN PERMISSION OF CNC BROACH TOOL LLC IS PROHIBITED.

UNLESS OTHERWISE SPECIFIED:		NAME	DATE
DIMENSIONS ARE IN INCHES		DRAWN	SMA 03/20/21
TOLERANCES:		CHECKED	XX XX/XX/XX
FRACTIONAL ± .005		ENG APPR.	
DECIMAL ± .001		MFG APPR.	
ANGULAR: MACH ± .1° BEND ± .2°		Q & A	
TWO PLACE DECIMAL ± .010		COMMENTS:	
THREE PLACE DECIMAL ± .005			
INTERPRET GEOMETRIC TOLERANCING PER:			
MATERIAL: 17-4PH S.S.			
FINISH: BLACK OXIDE			
DO NOT SCALE DRAWING			



TITLE: T12L BROACH TOOL DETAIL			
SIZE: B	DWG. NO.: T12L	REV: C	
WEIGHT:		SHEET 1 OF 1	